

**Operating Data:**

Flow Rate	180	$m^3/hr$
Discharge Head	20	m
Pump NPSHA	2.1	m
Pump NPSHR		
Efficiency	71.5	%
Design Speed	1465	rpm
Power Absorbed	13.7	kw
Pump Service	Continuos	

Location	-	
Pumped Product	Slurry	
Fluid Temperature	61	$^{\circ}C$
Fluid Density	1000	$Kg/m^3$
Fluid Viscosity	1	$mm^2/s$

**Design**

Impeller Diameter	294	mm
Number Of Vanes	2	
Direction of Rotation	Clockwise	
Suction Nozzel DN	125	mm
Discharge Nozzele DN	100	mm
Shaft Seal	Packing	

**Material**

Casing	GG25	Impeller	especial stainless steel
Suc. Side wear plate	especial stainless steel	Shaft	1.4021
Discharge Cover	GG25	Shaft protecting Sleeve	1.4122

**Coating:**

Primer	Ethylsilicate-High Zinc Content
Intermediate	Polyamide
Top Coat	Polyurethane RAL 5003

Customer: Hormozgan Steel Co.

Order No.: 112304

Offer ref: 9100002578



Flow: 180 m<sup>3</sup>/h

Total head: 20 m

Speed: 1465

Density: 1 gr/lit

## Performance Curve

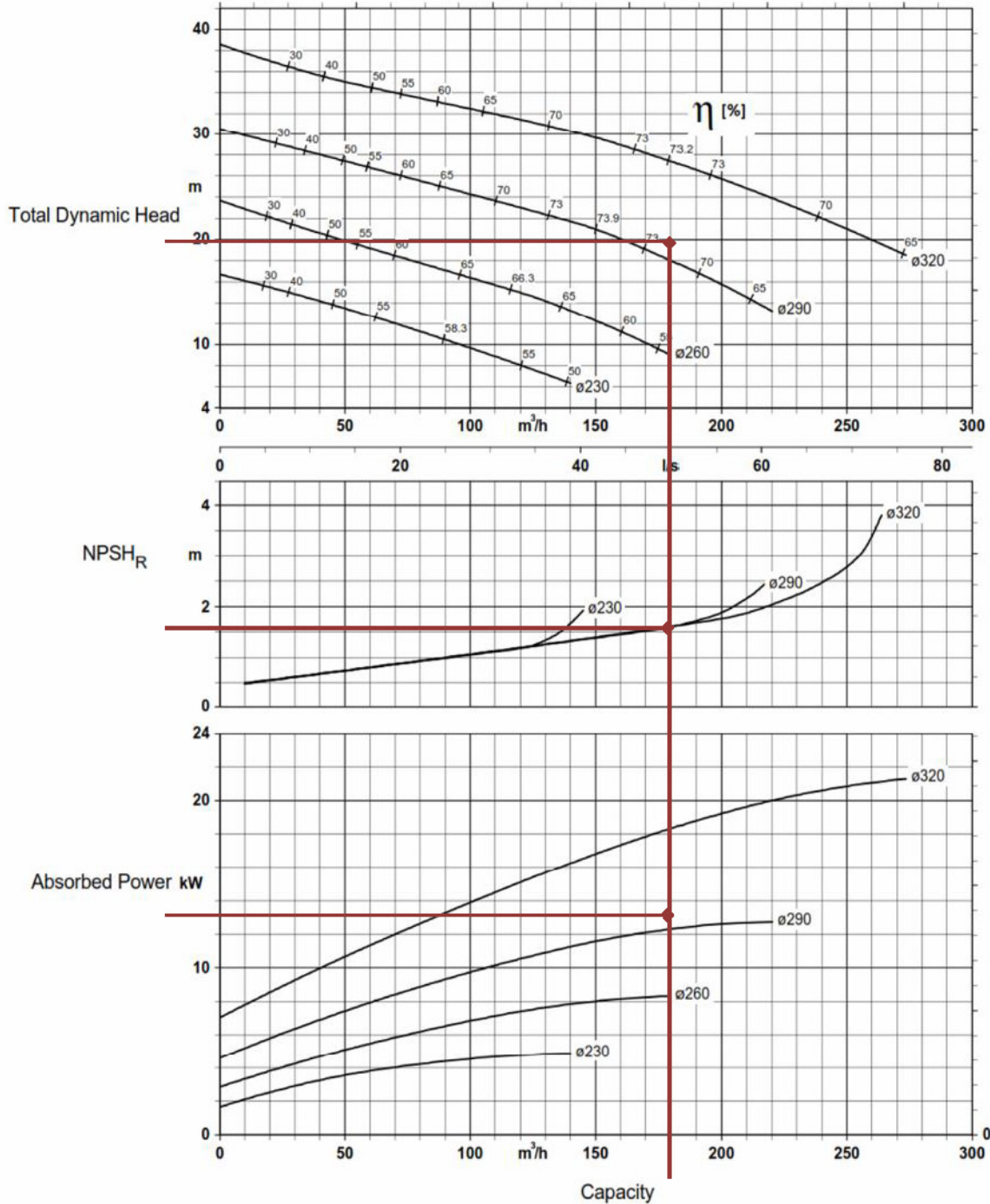

Rev	Date	Drawn	Checked	Approved

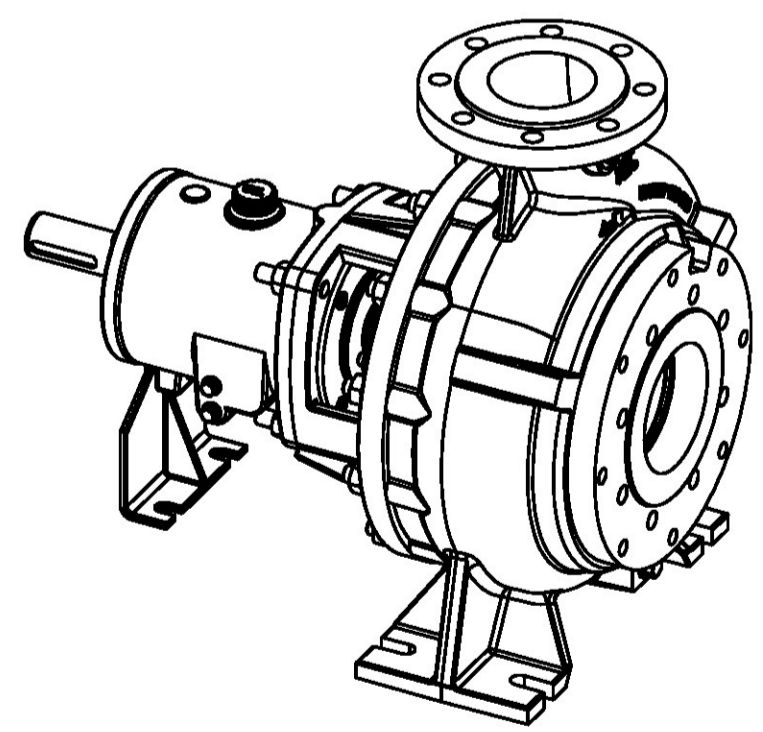
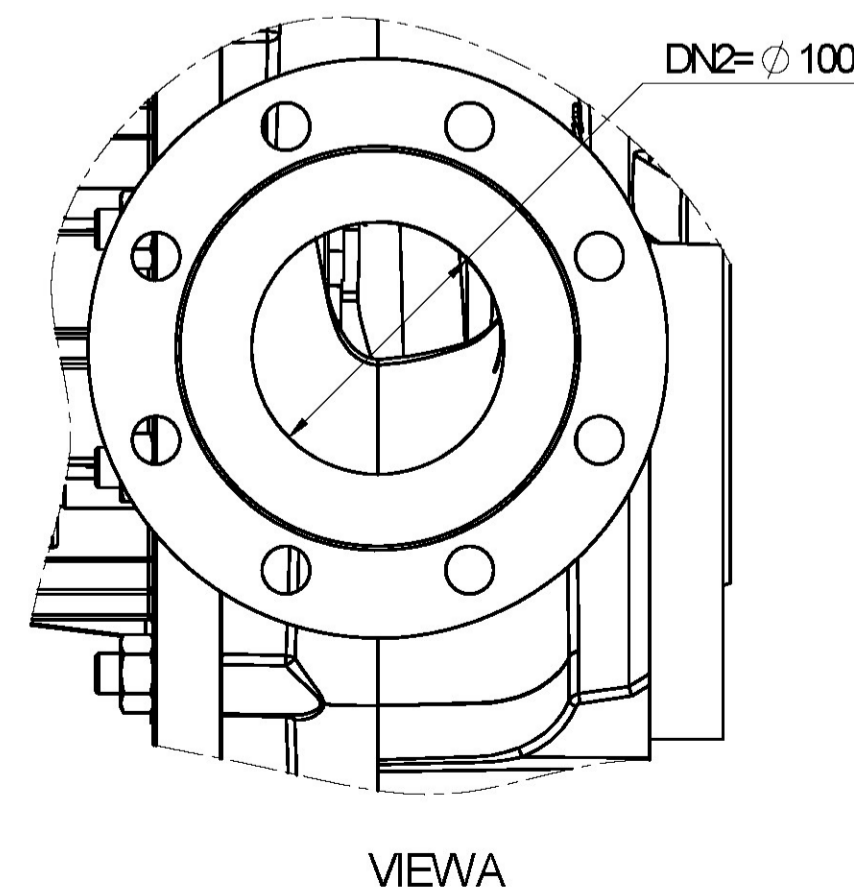
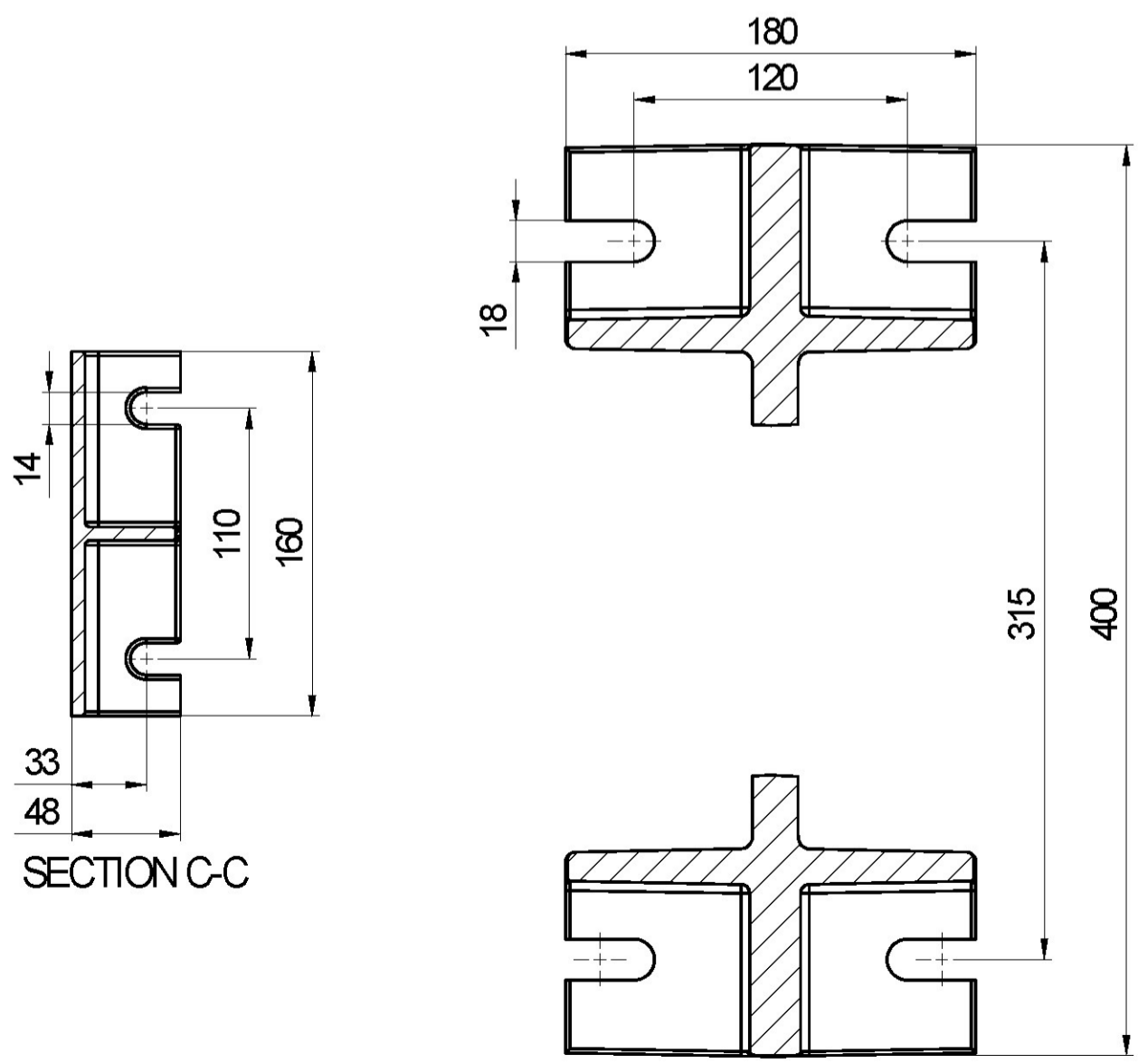
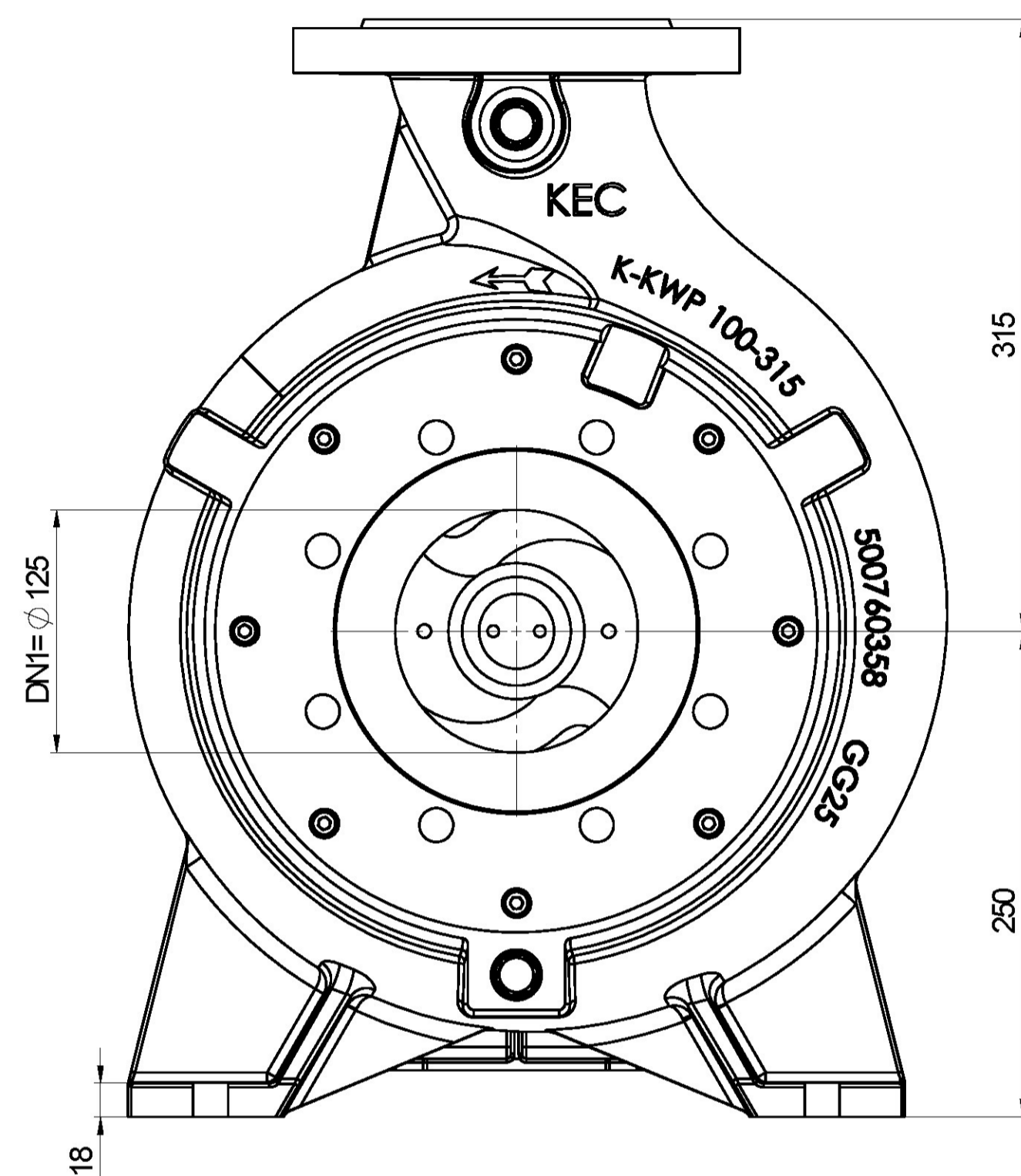
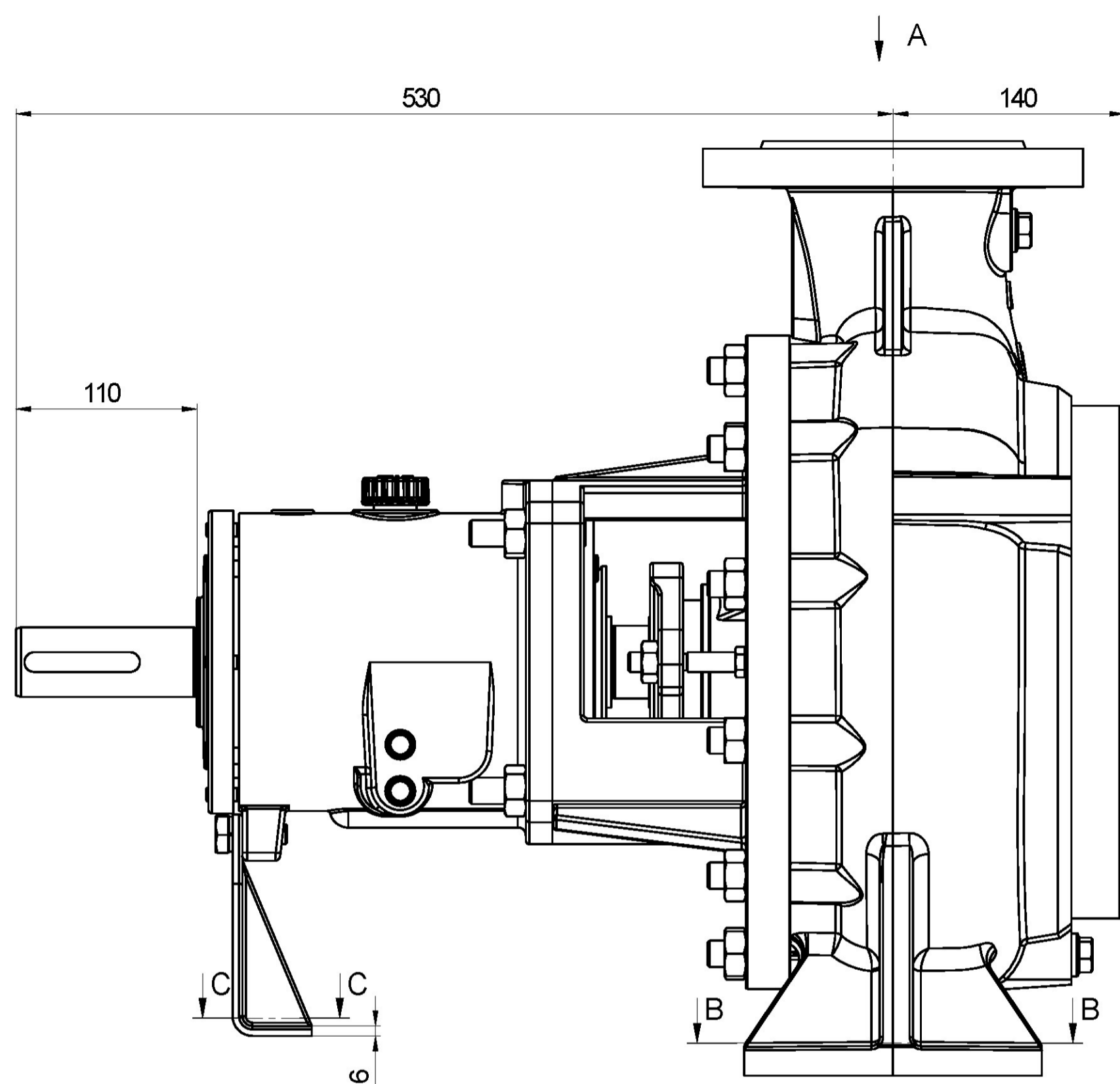

Product No.: K WPK 100-315	Designed	Date	Name	General Tolerances: ISO 2768-mk
Ref.Dwg.No.:	Drawn			SCALE: 1:2 Qty: 1 Weight: 168 (Kg)
Tag.No.: PU 37	Checked			Material-Code: Material No.:
Part No.:	Approved			Title: K WPK 100-315 Out Line Drawing
Order.No.: 112304				Drawing No.: REV
Sheet 1 of 1 Size A2 Unit mm				شرکت مهندسی ماهین های دوار خاور KHAVAR ENGINEERING CO.

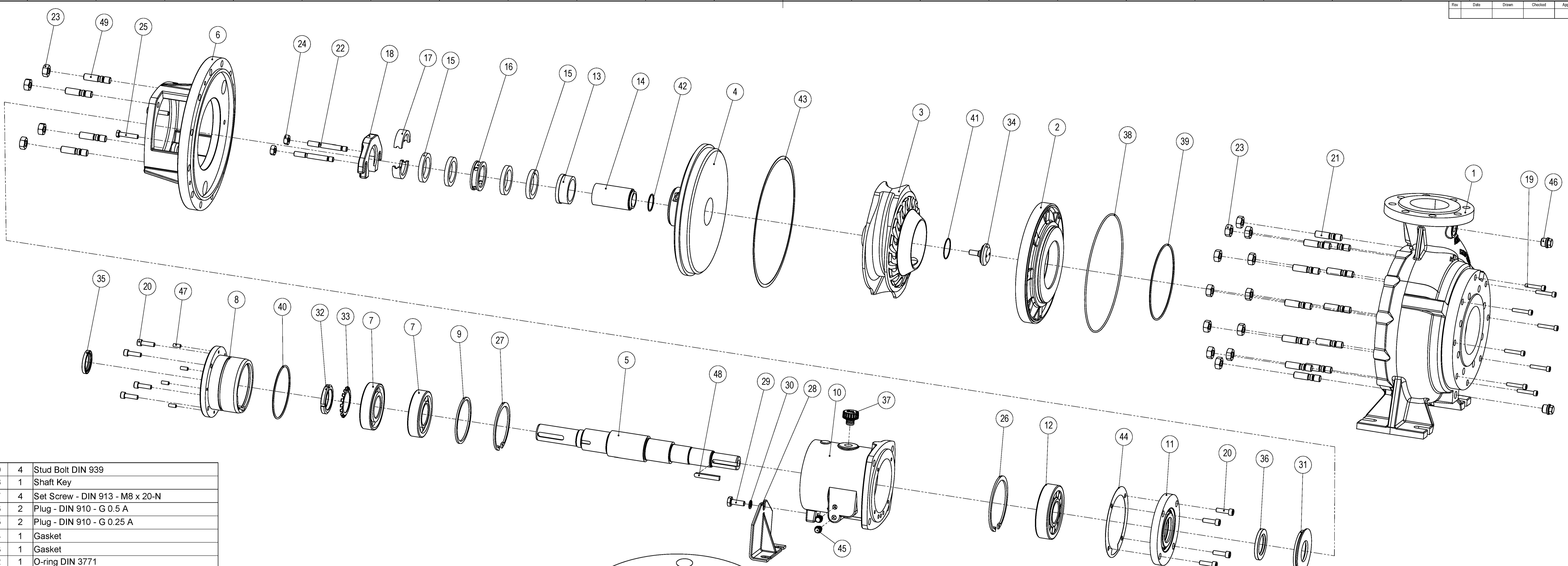

ITEM NO.	QTY.	DESCRIPTION
49	4	Stud Bolt DIN 939
48	1	Shaft Key
47	4	Set Screw - DIN 913 - M8 x 20-N
46	2	Plug - DIN 910 - G 0.5 A
45	2	Plug - DIN 910 - G 0.25 A
44	1	Gasket
43	1	Gasket
42	1	O-ring DIN 3771
41	1	O-ring DIN 3771
40	1	O-ring DIN 3771
39	1	O-ring DIN 3771
38	1	O-ring DIN 3771
37	1	Oil Plug
36	1	Lip Seal - DIN 3760 - AS - 55 x 80 x 8
35	1	Lip Seal - DIN 3760 - AS - 45 x 60 x 8
34	1	Impeller Screw
33	1	Luck Washer-DIN 981 - MB11
32	1	Luck Washer-DIN 981 - KM 11
31	1	Thrower
30	1	Spring washer-DIN 128 - A12
29	1	Screw-DIN 6914 - M12 x 35
28	1	Support foot
27	1	Circlip-DIN 472 - 120 x 4
26	1	Circlip-DIN 472 - 140 x 4
25	2	Screw-ISO 4014 - M10 x 50
24	2	Nut - M12 -DIN 6915
23	16	Nut - M16 -DIN 6915
22	2	Stud Bolt - DIN 939 - M12
21	12	Stud Bolt - DIN 939 - M16
20	8	Socket Head Cap Screw-DIN 912 M10
19	8	Socket Head Cap Screw-DIN 912 M8
18	1	Gland Cover
17	2	Lantern Ring (External)
16	1	Lantern Ring (Internal)
15	4	Packing
14	1	Sleeve
13	1	Neck Bush
12	1	Bearing- NU 411
11	1	Bearing Cover
10	1	Bearing Bracket
9	1	Support Disc
8	1	Bearing Carrier
7	2	Bearing -7311
6	1	Bearing Bracket Lantern
5	1	Shaft
4	1	Casing Cover
3	1	Impeller
2	1	Wear Plate
1	1	Casing

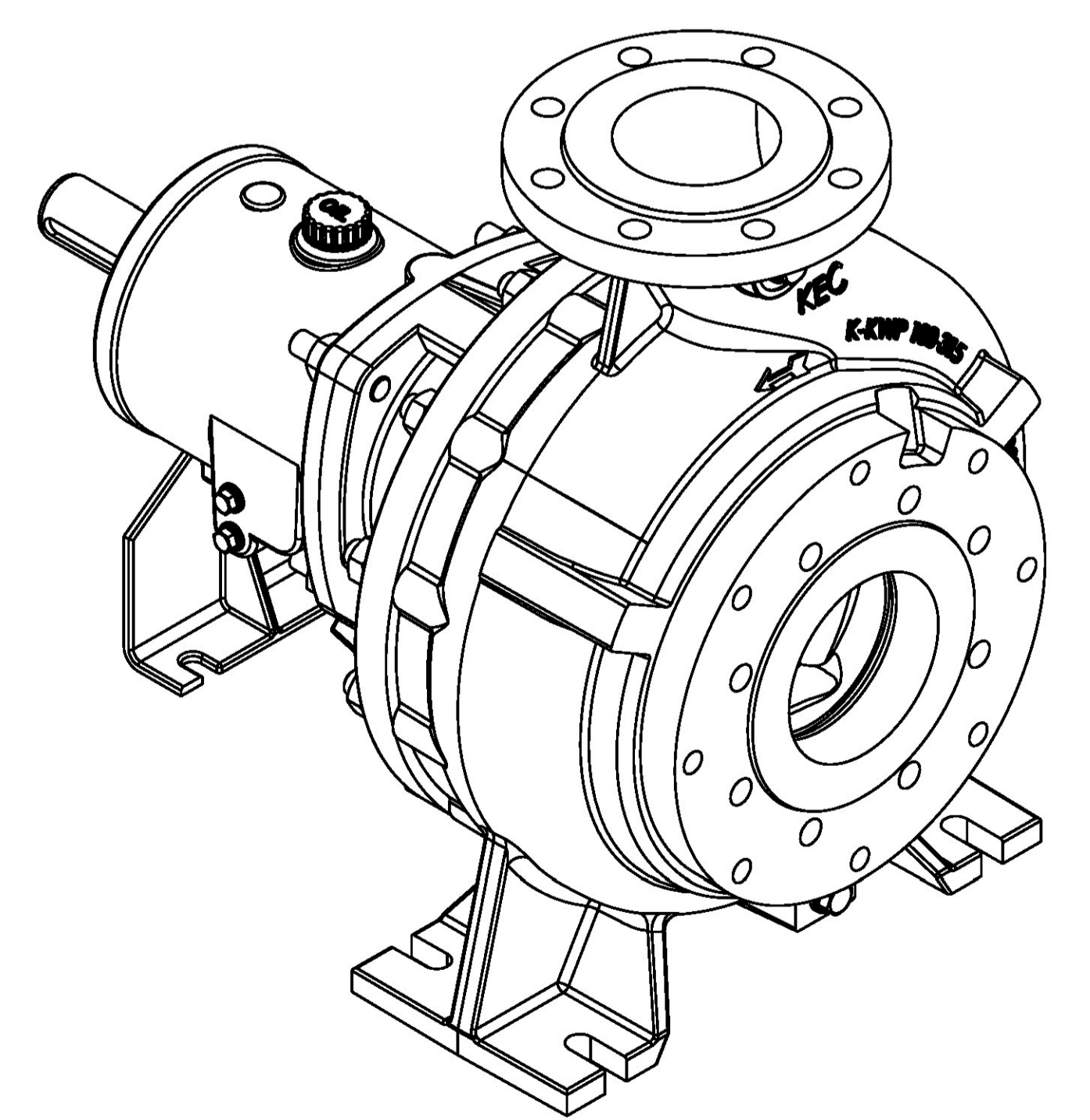
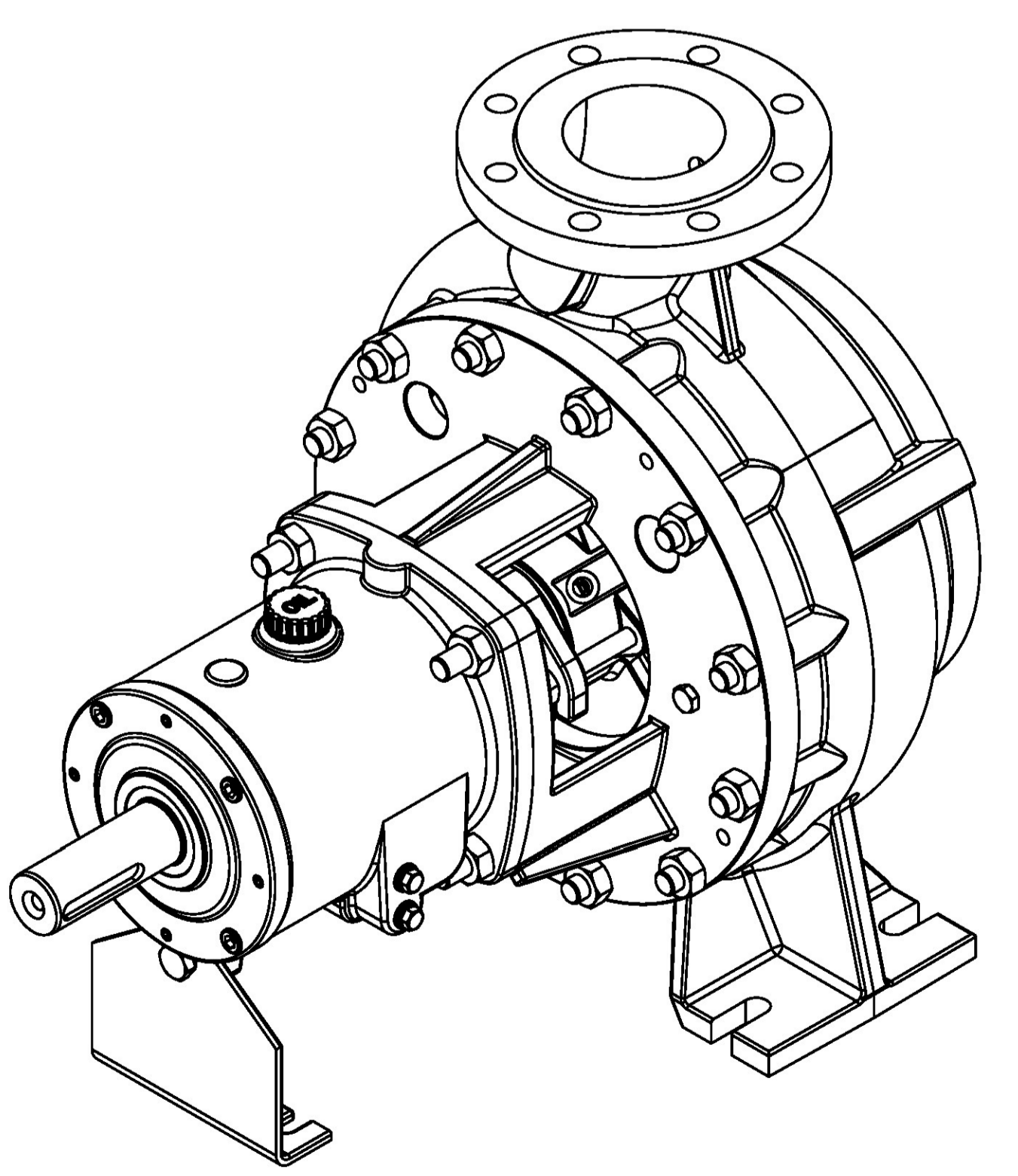
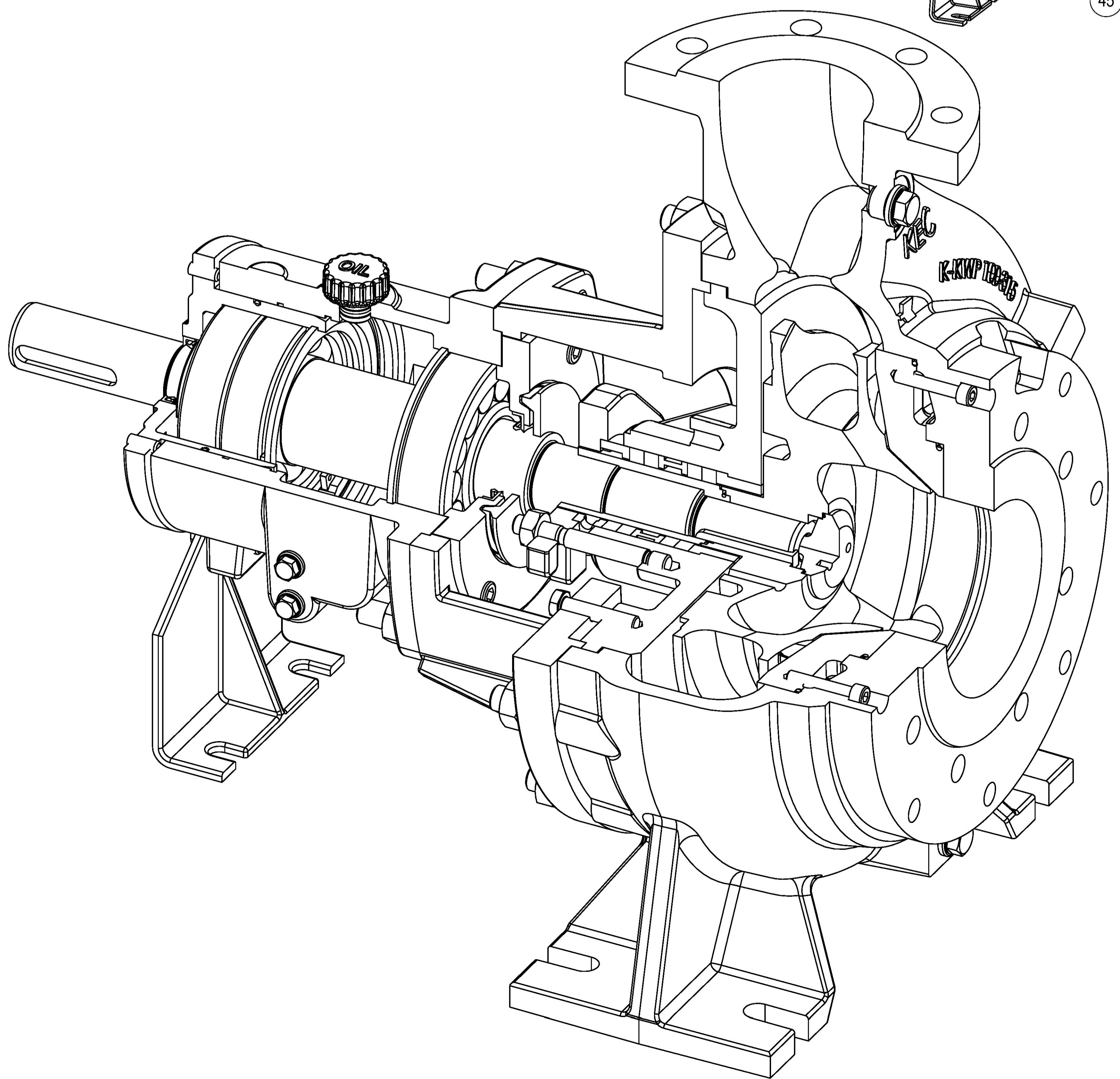

Product No:	KWP 100-315	Designed:	Date:	Name:	General Tolerances:	ISO 2768-mK
Ref Dwg No:		Drawn:			SCALE: 1:5	Qty: 1 Weight: 168 (Kg)
Tag No:	PU 37	Checked:			Material Code:	Material No: .....
Plant No:		Approved:			Title:	KWP 100-315 Explod View
Order No:	112104	Drawing No:		11010500176100035811000		
Sheet	1 of 1	Size	AD	Unit	mm	REV
1 of 1		AD		21		REV

